

GAMME LOW PROFILE LP

LP-F8 & LP-M8A GUIDE D'INSTALLATION

LP-F8 & LP-M8A Clips mâle et femelle auto-taraudeurs

LP-F8	UTILISÉ AVEC :	OUTILS D'INSTALLATION :				
	LP-M8A	CP-08ST	fraise de 25mm	CT-19	CT-09	CT-10
						

ÉTAPES D'INSTALLATION LP-M8A - Option auto-taraudeur

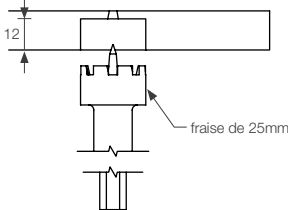
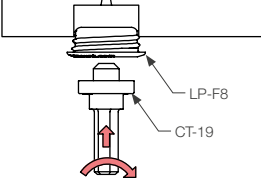
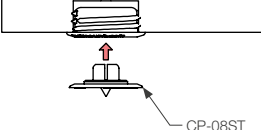
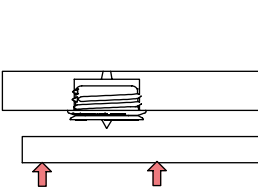
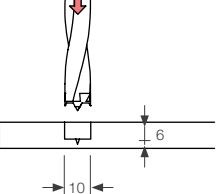
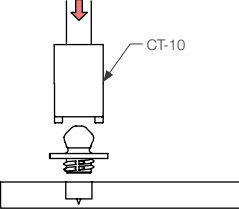
<p>1 Percer un trou de 25mm dans le support.</p> 	<p>2 Visser (auto-tarauder) le LP-F8A avec le CT-19 en utilisant un couple de serrage adapté.</p> 	<p>3 Insérer le CP-08ST dans le LP-F8A.</p> 
<p>4 Positionner, puis marquer le panneau.</p> 	<p>5 Percer le panneau sur le marquage avec le CT-09.</p> 	<p>6 Visser (auto-tarauder) le clip mâle avec le CT-10. Veiller à utiliser un couple de serrage adapté au panneau.</p> 

A Vue en coupe après montage.

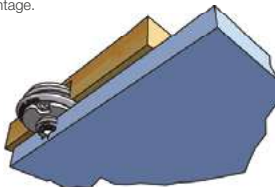



NB : Utiliser le CT-12 pour ébavurer le trou dans du stratifié sur 1 ou 2mm.

INFORMATIONS COMPLÉMENTAIRES : Guides de calepinage TD-02 & TD-08

GAMME LOW PROFILE LP

LP-F8 & LP-SM8A GUIDE D'INSTALLATION

LP-F8 & LP-SM8A Clip femelle auto-taraudeur et clip mâle à coller / visser

LP-F8	UTILISÉ AVEC :	OUTILS D'INSTALLATION :	
	LP-SM8AS	fraise de 25mm	CT-19
			

ÉTAPES D'INSTALLATION LP-SM8AS - Option à coller

- 1** Percer un trou de 25mm dans le support.

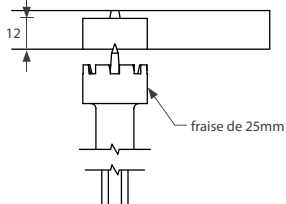

- 2** Visser (auto-tarauder) le LP-F8A avec le CT-19 en utilisant un couple de serrage adapté.

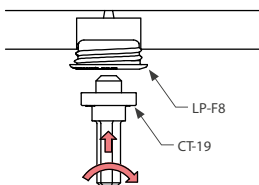

- 3** Insérer le LP-SM8AS dans le clip LP-F8.

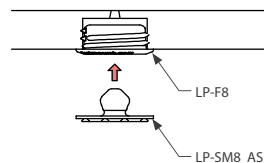

- 4** Appliquer la colle époxy sur l'embase du LP-SM8AS.

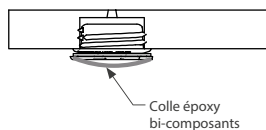

- 5** Positionner et maintenir le panneau en place.

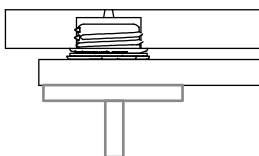

- A** Vue en coupe après montage (panneau retiré).

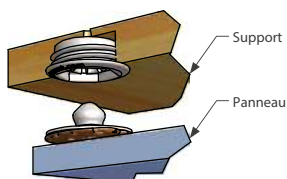

NB : Utiliser le CT-12 pour ébavurer le trou dans du stratifié sur 1 ou 2mm.

INFORMATIONS COMPLÉMENTAIRES : Guides de calepinage TD-02 & TD-08